

BAXI**INSTRUCTIONS**Solo Innova
EN/137409/00/24-06-2002.

Solo Innova

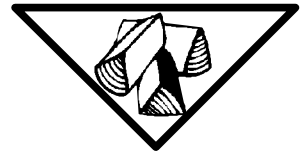

Wood-fired central heating boiler

	Section
User guide	1
Adjustment	2
Installation	3
Technical specifications and circuit and system diagrams	4
Installation protocol	5

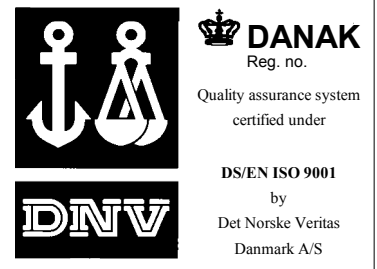

We hereby declare that BAXI product type

Solo Innova

complies with the following EEC directives:

- Council Directive 89/336/EEC of 3 May 1989 on the approximation of the laws of the Member States relating to electromagnetic compatibility as amended by 92/31/EEC and 93/68/EEC
- Council Directive 73/23/EEC of 19 February 1973 on the harmonisation of the laws of Member States relating to electrical equipment designed for use within certain voltage limits as amended by 93/68/EEC

CONTENTS

This user guide is divided into several sections. Figure numbers refer to the corresponding sections. Fig. no. 1.1.1 thus refers to Section 1.1.1. The symbol (#)-no. is used if several pictures belong to one section.

Section	Page
1 USER GUIDE.....	3
1.1 DESCRIPTION OF BOILER.....	3
1.2 SAFETY PRECAUTIONS.....	6
1.3 OPERATING HINTS.....	7
1.4 DESCRIPTION OF THE APPARATUS.....	10
1.5 TROUBLESHOOTING.....	12
1.6 MAINTENANCE.....	13
1.7 CLEANING.....	14
2 AUTOMATIC OPERATION – SAVING ENERGY.....	15
2.1 CONTROLLING THE BOILER WITH THE WEATHER COMPENSATION SYSTEM.....	15
3 INSTALLATION.....	16
3.1 STANDARDS AND REGULATIONS.....	16
3.2 SYSTEM TYPES.....	16
3.3 INSTALLATION.....	17
3.4 STANDARD DELIVERY:.....	17
3.5 INSTALLATION AND PIPE CONNECTIONS.....	17
3.6 EXPANSION TANK, SAFETY LINES AND PUMP SIZE.....	18
3.7 ELECTRICAL CONNECTION.....	18
3.8 COMMISSIONING THE SYSTEM.....	19
4 TECHNICAL SPECIFICATIONS AND CIRCUIT DIAGRAMS.....	20
4.1 BOILER TECHNICAL SPECIFICATIONS.....	20
4.2 CIRCUIT DIAGRAMS.....	21
4.3 SYSTEM LAYOUT.....	23
5 INSTALLATION PROTOCOL, BOILER SYSTEM.....	24
5.1 MEASURED AND SET VALUES.....	24

Specifications are subject to change without notice. No responsibility can be accepted for printing errors.

INSTALLATION GUIDE for BAXI - SOLO INNOVA boiler

The SOLO INNOVA is used to generate hot water. The permissible outflow temperature is 95°C and the permissible total excess pressure is 2.5 bar, measured at the deepest point in the boiler system/the boiler.

Please note the technical specifications which are given in the table below and the type plate.

The boiler should be installed as per the accompanying installation and user guide.

Please observe local regulations when installing the boiler and the heating system.

Regulation and limitation of the heating is by switching the fan by means of TR (temperature controller) and STB (safety temperature limiter). A max. draught of 20 Pascal may not be exceeded.

All boilers are given a water pressure test of 3.25 bar in the factory.

Apart from the accompanying installation instructions, a user guide with all requisite information must be kept at/hung on the boiler after the boiler has been set up.

1 User guide

1.1 Description of boiler

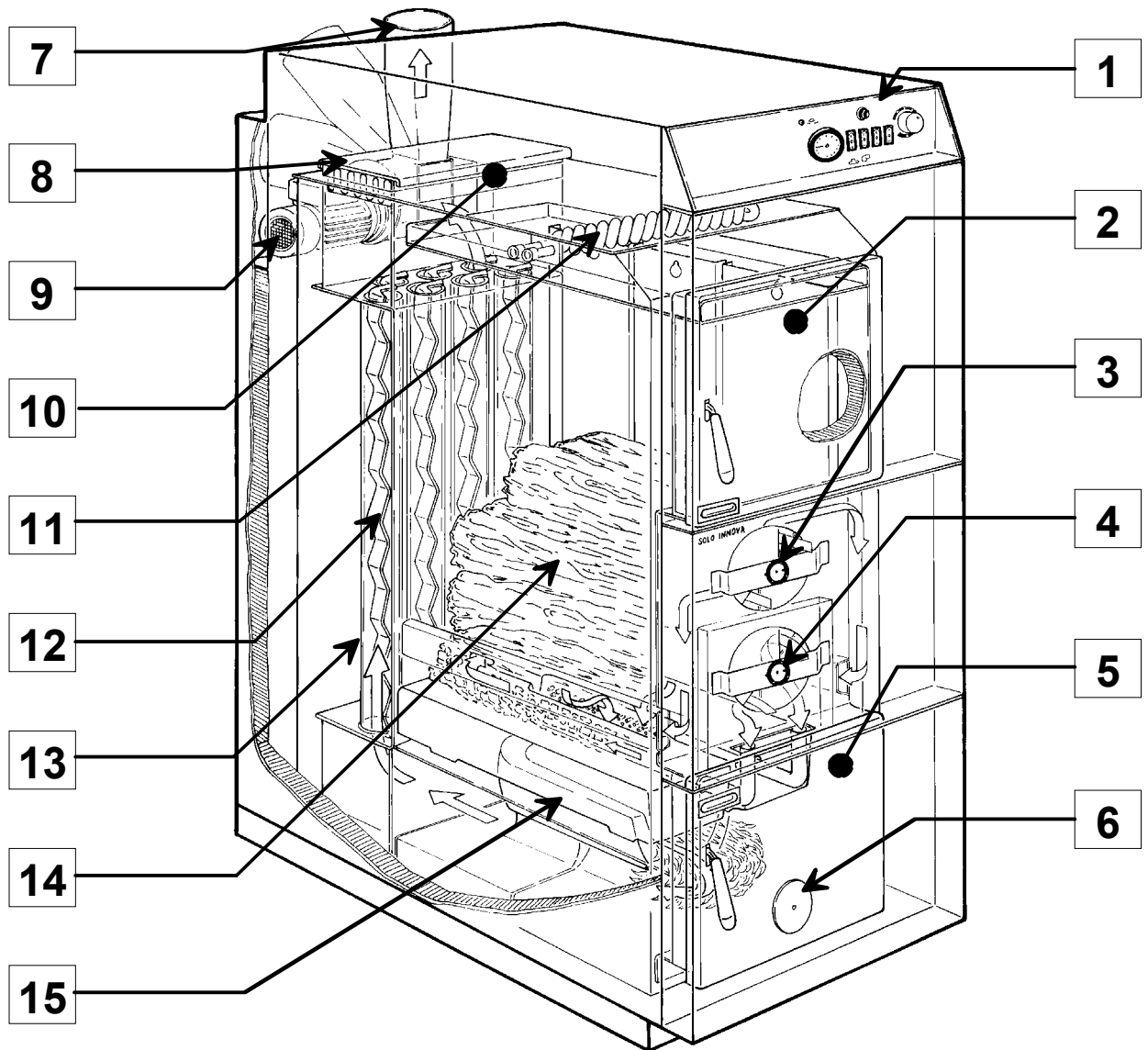

Fig. 1.1

1. Control panel
2. Filling door
3. Primary air control
4. Secondary air control
5. Ash door
6. Sight glass
7. Exhaust stack
8. Cleaning damper
9. Induced-draught fan
10. Type plate
11. Cooling spiral*
12. Flue gas turbulators
13. Heat exchanger pipe
14. Filling chamber
15. Fuel tunnel

*Can be installed to left or right.

1.1.1 Control panel (standard)

The boiler temperature is adjusted from here.
See also Section 1.4.

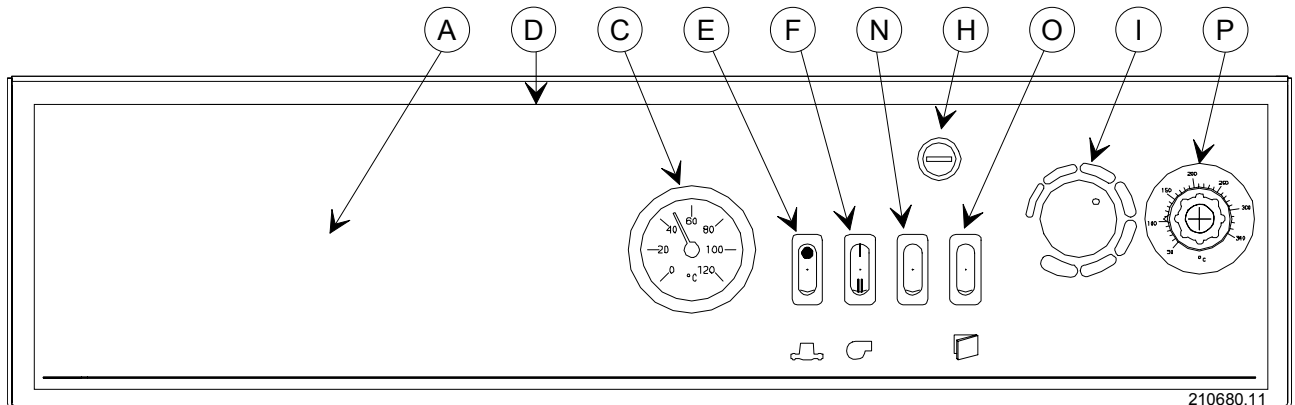

Fig. 1.1.1

- | | | | |
|-----|---------------------------------------|-----|--|
| (A) | Space for weather compensation system | (H) | Overheating thermostat – Restarting knob |
| (C) | Thermometer | (I) | Thermostat |
| (D) | Fuse | (N) | Reset switch |
| (E) | Switch for circulation pump | (O) | Switch to open door |
| (F) | Switch for fan | (P) | Minimum thermostat |

1.1.2 Filling door

The big filling door makes adding fuel easy.

1.1.3 Primary air control

The primary air of combustion is set here.

1.1.4 Secondary air control

The secondary air of combustion is set here.

1.1.5 Ash door

Combustion takes place behind this door and ashes are removed through it.

1.1.6 Sight glass

Combustion can be monitored through the sight glass.

1.1.7 Exhaust stack

An exhaust pipe is ducted to the chimney.

1.1.8 Induced-draft fan

Ensures the required air supply for combustion.

1.1.9 Cleaning damper

Detachable cleaning damper for cleaning the heat exchanger pipe.

1.1.10 Type plate

Indicates factory no. and type and other information required to order spare parts.
Factory no. and type can be noted in Section 5 on the last page of this user guide.

1.1.11 Cooling spiral

Thermal protection.

1.1.12 Flue gas turbulators

Ensure the correct flue gas temperature.

1.1.13 Heat exchanger pipe

The heat is transferred to the boiler water here.

1.1.14 Filling chamber

For the firewood.

1.1.15 Fuel tunnel

Air of combustion is added to the flue gases and they are burned here, ensuring high efficiency.

Description of more important components (layout see Fig. 1.1).

1.1.16 Function (See Fig. 1.1)



Fig. 1.1.16

The Solo Innova is made for burning pieces of natural wood. An important feature is the built-in induced-draft fan (9). Both primary and secondary air are added to the combustion chamber via an air channel at exactly the speed required for uniform combustion. The primary air (3) is ducted to the lower section of the filling chamber. The secondary air (4) is ducted further through the fuel tunnel, where it is heated and divided via two channels and the combustion nozzle. It is then blown directly into the flame at high speed to complete the combustion. A noteworthy construction feature is the special ceramic fuel tunnel (15) in the heart of the boiler which ensures that the combustion temperature reaches more than 1000°C. Combustion is efficient and soot-free, and ensures optimal economy. The heat is supplied to the boiler water via the heat exchanger pipe (13) at the rear of the boiler.

Mixing of the air of combustion from the fan and the gases from the wood in the correct proportions is a prerequisite for optimal and environmentally friendly burning of the wood with the highest efficiency.

Operation of the fan assumes that the boiler can discharge its heat continually. The Solo Innova must always be connected to a buffer tank of adequate size.

1.1.17 Maintenance and guarantee

The guarantee is described in more detail in the BAXI guarantee certificate supplied with the boiler. The guarantee is valid only when the system is connected to a buffer tank.

Complaints

Please contact the technician/dealer who installed/supplied your boiler, who will forward your complaint as required to the factory. Complaints may also be addressed directly to the factory.

1.2 Safety precautions

1.2.1 Responsibility

The operator is responsible for running the boiler and complying with firing instructions. Failure to comply with the instructions can result in reduced efficiency and increased environmental impact as the flue gases will not be as clean as they should be. Faulty operation can also reduce boiler life. Correct operation (and installation) is the best guarantee of long life and minimal impact on the environment. It is assumed that the operator possesses the appropriate motivation and the correct attitude for firing with wood, as a certain amount of work is still required to be able to “harvest” the advantages of this environmentally friendly and economical form of heating.

1.2.2 Safety precautions

If faults or defects are found, they must be promptly rectified by a qualified heating engineer. Flue gas pipes, ventilation channels, fresh air ducts etc. may not be closed off or blocked. Inflammable liquids or materials may not be placed near the boiler.

1.2.3 Maintenance

The operator must maintain and clean the boiler and any extra equipment in accordance with:

- general practice
- the instructions in this user guide
- the instructions for any optional equipment/accessories
- and the terms described in the appropriate guarantee certificate
- (see Section 1.7 Cleaning, 1.6 Maintenance and the boiler’s guarantee certificate).

1.3 Operating hints

1.3.1 Wood as fuel

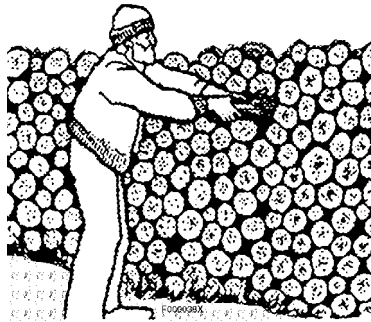

Chopped wood

The Solo Innova is made to burn natural forest wood. Both hardwood and softwood are suitable, but oak should not be burned as the only source of wood for long periods because of its high acid content.

The wood must be dry, i.e. moisture content 15-25%. The wood must be dry for good combustion and to achieve its best calorific value.

The wood will dry out most quickly if it is cut into the appropriate length and split into pieces 10-12 cm thick. The best length is 1/2 metre for the Solo Innova 30-50 and 1/3 metre for the Solo Innova 20.

The wood is best stored in the open air under cover, but it can also be stored uncovered. The wood will dry most quickly if it is carefully stacked alternatively lengthwise and crosswise so that air can penetrate into the stack.

The wood should be stored for at least one and a half years.

(e.g. waste wood and wood chips) are less suitable as fuel. On the one hand they can fall down the gap between the ceramic bricks and on the other hand it can be difficult to control the combustion process effectively. The disadvantages can, for example, include reduced efficiency, soot etc. Impregnated or painted wood is unsuitable as fuel. The Solo Innova is designed for forest wood. Wood is an environmentally friendly fuel as it is CO₂-neutral.

Briquettes

Wood briquettes or straw can also be used as fuel, e.g. with a diameter of 60 mm and a length of 50-100 mm.

Excessively small and compact pieces of wood or straw pellets are not suitable.

Coal

Coal cannot be used as it becomes too compact and closes the fuel slit.

Maximum fill height

The filling chamber can be filled to the top.

1.3.2 Before using

1. Check the water pressure before using the system.
 2. The pump and the fan must be switched off when filling with water. This is most easily done at the main switch on the wall. (See Section 1.6 - Maintenance).
- N.B.: Water may not be added to the boiler while it is running.
3. When filling, the system must be bled via the venting screw.

1.3.3 Commissioning the boiler

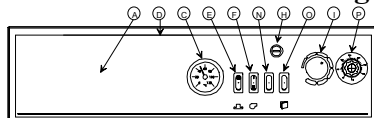

1. Switch on the main switch on the wall.
2. Fill with fuel (see Section 1.3.8 or 1.3.9).
3. Switch on the switches for the pump (E) and the fan (F). Set the thermostat (I) to the desired temperature. Press the reset button (N).
4. Light the fire as in Section 1.3.7.
5. The boiler will start if heating is required.
6. See Section 1.5 – Troubleshooting if there are problems starting.

1.3.4 Shutting down the boiler

1. Switch off the boiler at the main switch on the wall.
2. Then switch off the boiler/the circulation pump at switches (E) and (F).

1.3.5 Connecting a buffer tank

The correct proportions of air of combustion from the fan and gases from the wood are a prerequisite for optimal and environmentally friendly burning of the wood with the highest possible efficiency. Operation of the fan assumes that the boiler can continually discharge its heat. BAXI therefore recommends that a buffer tank always be connected.

1.3.6 Tar in the combustion chamber

Tar deposits are not normally a problem in a Solo Innova which is fired as directed (see section 1.3.12 – Operation with buffer tank).

1.3.7 Preheating

- 1) Switch on the fan with the switch on the control panel (F) (Setting I).
- 2) Press door open switch O and open the door.
- 3) Insert pieces of wood and paper.
- 4) Light the wood and the paper. Close the door.
- 5) Switch on the fan switch (F).
- 6) Press the reset switch (N). The fan will start.
- 7) Add fuel when the embers are about 150 mm high.

– Combustion will be in progress after about 5-10 minutes.

1.3.8 Putting in wood

It is very important not to add so much wood than that the heat of combustion cannot be stored in the reservoir. The maximum temperature should only be reached when the wood has burned. **THE FAN SHOULD NOT SWITCH OFF BEFORE THE WOOD HAS BURNED*) IF THE FAN SWITCHES OFF BEFORE THIS, THERE IS TOO MUCH WOOD. MAKE THE BEST POSSIBLE USE OF THE RESERVOIR AND DO NOT ADD TOO MUCH WOOD.** See also 1.3.12

*) Waiting time and starting/stopping of the fan do not give clean combustion. It is also bad for the boiler as condensation will occur in the filling chamber, causing corrosion in the steel walls.

1.3.9 Adding wood

- 1) Switch on the fan with the switch on the control panel (F) (Setting I).
- 2) Press the door open switch.
- 3) Open the filling door 2 cm with the left hand.
- 4) Wait about 20 seconds.
- 5) Slowly open the door.
- 6) Add wood. Try to stack the wood as evenly as possible.
- 7) Close the door.
- 8) Switch on the fan switch (F).
- 9) Press the reset switch (N).

1.3.10 Daily firing and warming up

The warming up procedure for daily use is the same as was done the first time. Use pieces of wood and paper. Stir up the ashes when the fire is underway. Add more wood, close the door and switch on the fan. The newly added wood will now ignite.

Operation

The fuel tunnel (behind the ash door) must be kept reasonably free of ashes and small half-burned pieces of wood. Use the scraper to keep the tunnel clean and leave the small pieces of wood in front of the tunnel, where they will burn. It is useful to check the tunnel each time it is warmed up and to clean carefully as required.

Storing the fuel. Wood may not be stored in the boiler room. The wood is best protected from rain, stored under cover.

1.3.11 Transport protectors

The transport protectors for the ceramic bricks are made of wood and will quickly burn. Do not try to remove them.

1.3.12 Operation with buffer tank

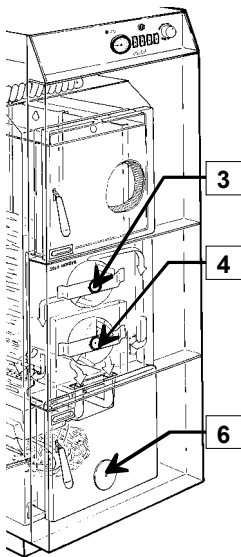

- BAXI recommends permanent connection of a BAXI buffer tank (see Section 4.3):
- The boiler will always be able to discharge its heat.
 - Better combustion, less depositing of soot and tar, longer boiler life.
 - Simpler operation as the filling chamber can be completely filled.
 - The boiler can be fired when you have time and the house can be supplied with heating as required from the buffer tank.
 - Hot tap water from a container in the buffer tank (BAXI will be happy to assist with calculating the buffer tank size).
 - The amount of wood placed in the boiler's filling chamber depends on the size and the temperature of the buffer tank. The boiler should not be fired beyond the reservoir's heat storage capacity.
 - Do not add wood until the temperature in the buffer tank has fallen to 40-50°C so that the reservoir will again be able to absorb heat.
 - Set the boiler temperature to 90°C, i.e. almost maximum.
 - Clean the boiler regularly (see Section 1.7).

Fig. 1.3.13#1

1.3.13 Adjusting combustion

Manual air setting – standard values		
Boiler type	Primary air (damper 3)	Secondary air (damper 4)
Hardwood (beech and birch)		
-Solo Innova 20	50%	50%
-Solo Innova 30	50%	50%
-Solo Innova 50	75-100%	75-100%
Softwood (conifers)		
-Solo Innova 20	100%	0-10%
-Solo Innova 30	100%	0-10%
-Solo Innova 50	100%	20%

The Solo Innova features primary and secondary air combustion for optimal burning. Combustion is controlled with primary air adjustment 3 and secondary air adjustment 4. Both are normally 75% open*). Combustion is stable after about 45 minutes of operation and the secondary air may be turned off. Observe the combustion through the sight glass 6. The flame should be yellow and pale bluish, and the flame length should be appropriate (see below). It is normally only necessary to adjust the setting if the fuel is changed.
*)If full output is required, they can be opened 100%.

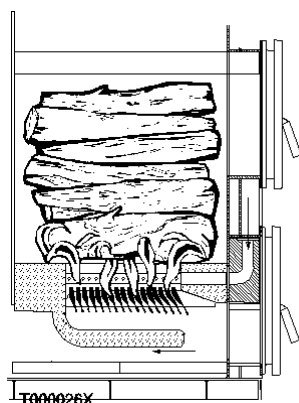

Fig. 1.3.13#2
Too much air.
Flame too short and bluish.
Reduce secondary air.

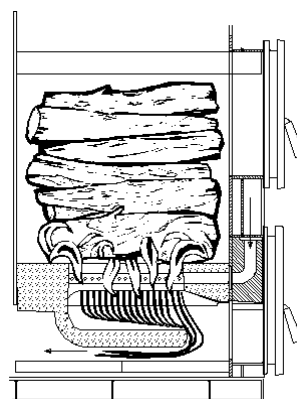

Fig. 1.3.13#3
Too little air.
Flame too long and reddish yellow.
Increase secondary air.

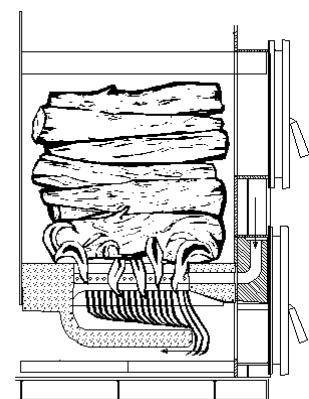

Fig. 1.3.13#4
Correct setting.
The flame is yellow and pale bluish.

1.4 Description of the apparatus

1.4.1 Control panel – the boiler temperature is set from here.

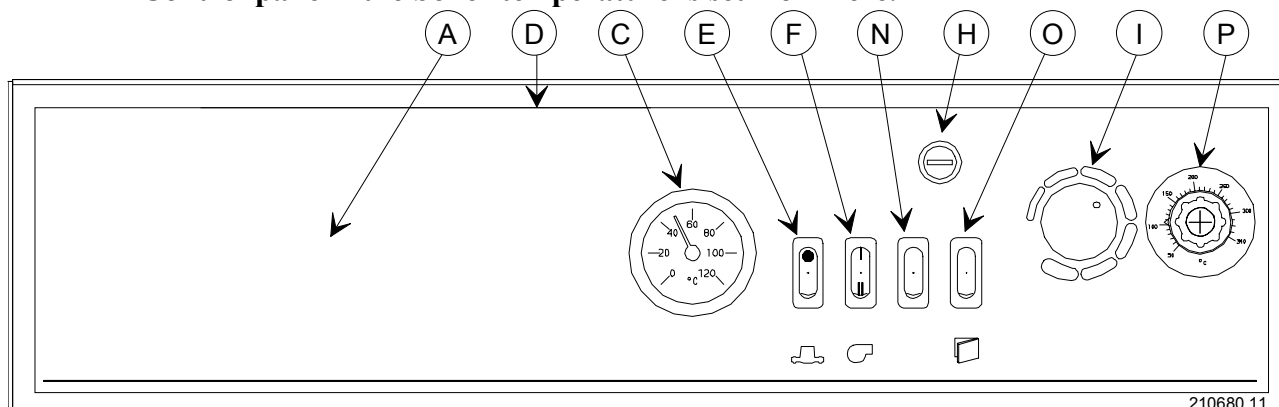

Fig. 1.4.1

- | | |
|---|--|
| (A) Space for weather compensation system | (H) Overheating thermostat – restarting button |
| (C) Thermometer | (I) Thermostat |
| (D) Fuse | (N) Reset switch |
| (E) Switch for circulation pump | (O) Door open switch |
| (F) Fan switch | (P) Minimum thermostat |
- (A) Space for weather compensation system.
- (C) Thermometer. Shows the boiler temperature. The boiler temperature is adjusted via thermostat (I).
- (D) Fuse max. 6.3 A (5 x 20 mm).
- (E) Switch for circulation pump.
- (F) Fan switch (should always be set at I).
- (H) Overheating thermostat – switches off the fan when the boiler temperature is approx. 100°C. Wait until the boiler temperature has fallen to 75°C. To switch on again, unscrew the protective cap and push in the ejected pin.
- (I) Thermostat 85-93°C. Recommended set temperature 85-90°C.
To ensure that the temperature is not set at less than 80°C, a stop screw is mounted under the knob.
- (N) Reset switch. The fan switches off automatically if the boiler has burned out and the boiler/flue gas temperature falls.
- In units with buffer tank, the fan switches off when the temperature at the sensor in the flue gas has reached 90°C.
 - If the temperature at the sensor falls below 90°C, the reset switch (N) must be pressed to restart combustion in the boiler.
- (O) Door open switch – ensures that children cannot open the door.
Activating the switch releases an interlock in the upper cover door.
- (P) The minimum thermostat switches off the fan and the pump when the wood has burned out.

1.4.2 Fan

The total air flow is set at the factory.

1.4.3 Thermal outflow protection

The standard version of the Solo Innova does not have a cooling spiral. This spiral can be mounted to the left or the right.

1.4.4 Flue gas turbulators

The flue gas turbulators are in the heat exchanger pipe and reduce the flue gas temperature.

1.4.5 Load valve

The thermostatic load valve enables the boiler to remain at a high temperature. As the valve only opens at 65°C, the boiler thermostat must be set higher (i.e. fixed max. 90-95°C). The load valve is supplied as a separate valve or as a complete pipe complex ready for installation in the boiler. (See functional description of the load valve in Section 4.3).

The guarantee is not valid unless a thermostatic load valve is installed.

1.4.6 Draught limiter

If the chimney draught is excessive, a draught limiter can be built into the chimney (see Section 3.3.3).

1.5 Troubleshooting

1.5.1 Troubleshooting

Problem Problem
No.

Possible cause/==> possible solution

1. No heat in the system

- A: Thermostat (I) set too low.
→ Set thermostat higher.
- B: Fan cut out because the min. thermostat temperature has fallen below 90°C.
→ Press reset switch (N).
- C: Overheating thermostat triggered.
→ Press knob in again.
- D: Mixer (if present) fully or partly closed.
→ Open.
- E: Circulation pump not running.
→ Switch on.
- F: Insufficient water in the system; air in the system.
→ Top up and bleed.
- N.B.: Never add water to an overheated boiler.
Wait until the boiler has cooled down.
- G: Regulator may have switched off the system.
→ See user guide for regulator.
- H: Fuse (D) blown.
→ Replace fuse in boiler control
(see Fig. 1.4.1).
→ Call a serviceman if you cannot determine the cause.

2. Combustion will not stop.

If combustion continues despite switching off the fan at the thermostat (I) or the switch (F), the problem may be an excessive chimney draught.
→ If this is the cause, a draught limiter should be built into the chimney. Consult your serviceman and chimney sweep about purchase and installation (see Section 3.3.3).

3. Loss of pressure in the system.

Bleed the system and add water.
(See Section 1.6 Maintenance)
→ Call a serviceman if the pressure continues to fall.

4. The fan does not switch off although the min. thermostat temperature has fallen below 90°C.

If the boiler is operated from cold, the boiler temperature must reach normal operating temperature (above 80°C) to switch over the min. thermostat. If normal operating temperature is not reached, the fan will not switch off but continue to run, even though the wood has burned out and the min. thermostat temperature has fallen below 90°C.
→ Ensure that the boiler is brought to normal operating temperature (about 85-90°C) each time it is used.

1.5.2 Maintenance tips

What causes poor boiler performance and why doesn't the flame length in the fuel tunnel change when the adjustment for secondary air is changed?

It is important to use wood of an appropriate size (length and diameter) and to stack it properly so that there are no "holes" and "hanging pieces" in the wood stack, which must then be regularly stirred with the poker to form it into a compact mass.

The diameter of the wood may not exceed 10-12 cm as "holes" would then form more easily in the wood layer, creating a risk of reduced heating output. Thick pieces of wood must be split to a diameter of 10-12 cm.

See Section 1.3.13 for correct flame length.

1.6 Maintenance

1.6.1 Adding water

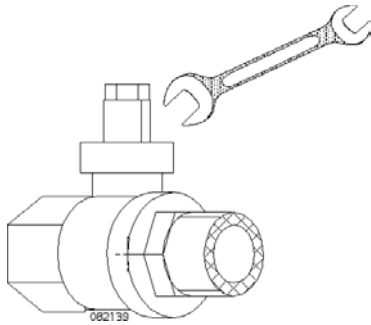

Fig. 1.6.1

The pump and the fan must be switched off when adding water to the system. It is easiest to switch off the main switch on the wall, so that all pumps and the fan etc. are switched off.

N.B.: Do not add water to an overheated boiler in operation.

Water may be added via the KFE cock (Fig. 1.6.1) with the aid of a hose connected to the tap. The hose must be filled with water before connection so that no air can enter the system.

First open the KFE cock. Then slowly turn on the water tap and fill the system until the water runs out of the expansion tank overflow. Then turn off the tap followed by the KFE cock. The system must be bled via the venting screw during filling.

1.6.2 Protection against freezing

The central heating system can be protected against freezing with anti-freeze, but please note that this does not protect the cooling spiral. If you desire protection against freezing, we recommend calling a serviceman to add the anti-freeze.

1.6.3 Replacing the door seals

1. Remove the two pins and take off the door.
2. Remove the old sealing with a screwdriver or a chisel.
3. Clean the sealing groove.
4. Press new sealing into the groove. When half the sealing has been inserted, adjust the end and press in the rest.
5. Secure the sealing by gently tapping with a hammer.
6. Replace the door.

1.6.4 Replacing the fuel tunnel

If the fuel tunnel has to be replaced, directions are supplied with the packet of replacement bricks.

1.6.5 Good advice

Keep the temperature at about 20°C in occupied rooms and lower in unused rooms. Give the house a quick but effective airing every day. Turn off the boiler while doing so.

DO NOT FORGET to check any safety valves and anode in any connected hot water reservoir.

1.7 Cleaning

The boiler must be cleaned regularly. Lack of cleaning can result in malfunctioning and reduced life.

1.7.1 Flue gas collection box and heat exchanger pipes

Clean the flue gas collection box and the heat exchanger pipes twice a month with the brush. Insert the brush into each heat exchanger pipe and work back and forth thoroughly.

Push the brush all the way through, but be careful not to damage the bottom plate underneath. A rotating cleaning brush for a drill (min. 400 watt) is available as an optional extra. This enables easier and more effective cleaning. Clean heat exchanger pipes and a clean flue gas collection box mean better operating economy.

1.7.2 Combustion chamber/filling chamber

Clean the combustion chamber/filling chamber once or twice a month. From the top filling door, scrape the ash through the fire gap with the scraper. The ash is then scraped out forwards from the ash door on to the boiler floor, and then out into the ash box.

Extra walls

Extra walls are fitted in the filling chamber (C - Fig. 1.7.2). These should be taken off once a month and any deposits behind them cleaned.

The ventilation holes in each side should be kept open.

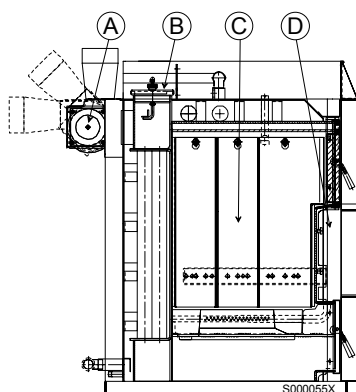

Fig. 1.7.2

1.7.3 Fan and air damper

The impeller (A - Fig. 1.7.2) must be inspected regularly and cleaned as necessary with a stiff brush (about four times a year).

Please check carefully – even a thin coating significantly reduces the air flow and must be removed.

When the exhaust stack is connected vertically directly under the chimney, the fan must always be removed and cleaned after each cleaning of the chimney.

N.B. If the fan motor is blocked because of lack of cleaning, the motor can be ruined.

1.7.4 Cleaning the air channels

The primary air channels (on both sides of the boiler) can occasionally become blocked. Before the air channels can be cleaned, the diffuser (A - Fig. 1.7.2) must first be removed (4 nuts). The air channels can be cleaned with the brush provided. The diffuser should be reinstalled with care. Remember the seal.

1.7.5 Removing the ash

The ash from the heat exchanger pipes and the combustion chamber is scraped out through the ash door and into the ash box with the aid of the scraper provided (or a vacuum cleaner may be used).

1.7.6 Cleaning the casing

Soot on the casing and the doors can be removed with a cleaner containing ammonium chloride and acetic acid. Clean the casing regularly as required to preserve the boiler's appearance.

2 Automatic operation – saving energy

The boiler is highly efficient and well insulated. Significant savings can nevertheless be made by automating the boiler's operation, i.e. no heating in the house during periods when it is not necessary.

2.1 Controlling the boiler with the weather compensation system

BAXI offers several brands of weather compensation system.

The equipment consists of:

Control unit (for installation in the control panel).

Mixer motor (for connecting to the mixer. The motor can be installed on a mixer which is already built in without emptying the system.)

Outside temperature sensor (for mounting on a north wall).

Outflow temperature sensor (for installation in the outflow line after the mixer).

The outflow temperature is automatically adapted to the outside temperature.

The control unit has a built-in seven-day clock, permitting a lowering of the temperature to be set separately for each day. As the Solo Innova must always be able to discharge its heat, the weather compensation system is recommended only for the buffer tank mixer.

3 Installation

3.1 Standards and regulations

3.1.1 Boiler room

The boiler should be set up in a separate boiler room.
Ensure that there is a proper supply of fresh air for correct combustion.
Set up the boiler in the boiler room.
Because of the noise made by the fan motor and the combustion (about the same level as in a modern oil-fired boiler), installing the Solo Innova close to a room where noise may be a problem is not recommended.
Please observe the guidelines and the various national and local regulations.
Solo Innova boilers are designed and approved as heaters for hot water systems with permissible outflow temperatures of up to 95°C.

3.1.2 Firing with wood

A large number of different gases is generated when wood burns. These gases constitute the main part of the wood's calorific value and contain formic and acetic acids. When the boiler fan is running, the gases are mixed in the correct proportions with air of combustion at high temperature. Combustion is then very efficient and soot-free, there is optimal economy of combustion (high efficiency), and boiler life is preserved. At the same time, the environment is best protected, as the tar and dust etc. content in the flue gas is low.
Optimal and environmentally friendly burning of the wood requires mixing of the air of combustion from the fan and gases from the fuel in the correct proportions. Fan operation assumes that the boiler can always discharge its heat, and **BAXI therefore always recommends that the Solo Innova be connected to a BAXI buffer tank.**

3.2 System types

3.2.1 Operation with buffer tank

BAXI recommends permanent connection of a BAXI buffer tank to the Solo Innova. See system diagram Section 4.3.
This offers the following advantages:

- The boiler can always discharge its heat.
- Improved combustion, greater efficiency, lower fuel consumption.
- Better environmental protection, less soot and tar build-up.
- Longer boiler life.
- Greater operating comfort. Firing occurs when required. The filling chamber can be filled completely. The buffer tank provides the house with heating/hot water as required.

3.2.2 Buffer tank size

BAXI supplies complete buffer tanks in sizes 500 and 750 litres, with and without built-in hot water reservoir. Types 500 B and 750 B with hot water reservoirs are equipped with two connections for installing electric heating elements. The buffer tanks are heavily insulated with CFC-free polyurethane foam.
If buffer tank size is to be determined by ease of use and boiler operating conditions, a minimum reservoir volume as specified in the table in Section 4 (Technical specifications) is recommended.
BAXI will be happy to assist in calculating the reservoir size if a bigger buffer tank is desired in order to cover heating and hot water requirements over a longer period.

3.2.3 Load valve

The guarantee is not valid unless a thermostatic load valve is installed (see Section 1.4.5 and the tables in Section 4.3).

3.3 Installation

Boiler size should correspond with the house's heating requirements and not be made to depend on the size of the filling chamber.

3.3.1 Who may install the boiler?

The heating engineer must possess the necessary training and authorisation to install the boiler.

3.3.2 Chimney and chimney draught

The flue gas temperature in a clean boiler is about 150°C.

The chimney should be able to accommodate this temperature.

As the Solo Innova has a built-in fan, only minor demands are made on the chimney draught. The correct chimney draught is 10-15 Pascal. The chimney can therefore be lower than for the usual solid fuel boilers. Relevant standards and regulations must be observed for the chimney shape. An excessive diameter or inadequate insulation can result in sooting. Please consult a chimney sweep.

We recommend connecting the boiler's exhaust stack back to the chimney at an angle or horizontally.

The exhaust stack can also be connected vertically, but the fan impeller must then be removed each time the chimney is cleaned and ash/soot removed.

3.3.3 Excessive chimney draught → draught limiter

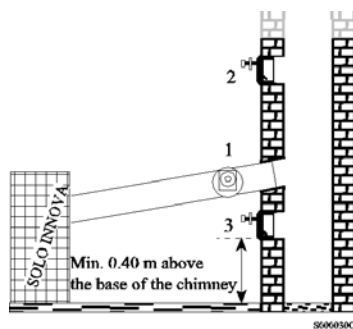

Strong directional wind or a very high chimney can cause such a high chimney draught in some circumstances that combustion continues even though the fan has been switched off. The solution here is building in a draught limiter so that the chimney draught can be set to 10-15 Pascal. The chimney sweep should be consulted first. A draught limiter is available from BAXI as an accessory for the boiler (A solid draught limiter in stainless steel with outer bearing and good control accuracy). The draught limiter can be built in, in positions 1-2 or 3.

Fig. 3.3.3

3.4 Standard delivery:

- Boiler without casing
- Casing
- Cleaning tool
- Ash box
- Boiler regulator

3.5 Installation and pipe connections

3.5.1 Installation

- Set up the boiler on a stable base.
- Adapt the connector to the chimney.

3.5.2 Casing installation

1. The suction draught fan must be installed (with four wing nuts and washers) before the casing is attached.
2. The casing should be attached as indicated in the accompanying photographic instruction.
3. Place the sensors into the immersion tube. The capillary pipe must be bent carefully and "softly". The long thin sensor should be placed in collar no. 12 for the suction draught fan – see Section 4.1, Technical specifications. Place the other sensors in the immersion tube (21) – see Section 4.1.
4. Connect pipes.
5. Connect power.
6. Install the casing cover and tighten with the four screws.

3.5.3 Pipe connections – choice of material

A copper/steel mixture can be used for the heating side.
The built-in heat exchanger is made of copper.
Copper followed by galvanised piping (in the direction of the water flow) should be avoided for hot water for reasons of corrosion protection. However, galvanised cold water piping and copper piping can be used for hot water.
The out- and return flows must be carefully insulated to avoid heat loss.

3.5.4 Immersion tubes and collars

Remember to install the immersion tube provided in the corresponding collar.
(Immersion tubes are supplied with the boiler regulator.)

Remember to cap collars which are not used in the chosen form of installation.

3.5.5 Protection against freezing

The central heating system can be protected against freezing with anti-freeze (see 1.6.2).

3.6 Expansion tank, safety lines and pump size**3.6.1 Expansion tank**

The size of the expansion tank is determined by the total water content of the heating system.

3.6.2 Safety valves and safety leads

Provide safety valves, overflow from safety valve, running-dry protection and expansion tank in accordance with applicable standards and regulations.
Safety valves and running-dry protection should be installed directly at the flow pipe (no valves).

3.6.3 Pump size

The size of the circulation pump is determined by the size of the system and the pipe dimensions and version.

3.7 Electrical connection**3.7.1 Electrical connection**

The boiler is connected via the cable supplied: phase/neutral and earth.
There must be a cut-out in the permanent installation.
See Section 4 for circuit diagrams.

3.7.2 Description of functions

(See circuit diagram Section 4. Note in brackets (see Section 1.4).
To start the boiler from cold, the reset switch (N) S7 must be pressed, after which:
- Relay K2 cuts in
- and remains active for the time being.
- K2 switches fan M6 and circulation pump M7 on.
When the boiler temperature reaches the min. thermostat setting - B15
- K2 cuts out.
Boiler thermostat B16 then regulates the boiler.
If the boiler temperature again falls below the setting in min. thermostat B15
- Fan M6 is switched off.
- Circulation pump M7 is switched off.
If the boiler temperature reach the coupling point of the boiler thermostat B16 (app. 85-93°C) the pump M7 will be switched on again in order to lead supplies of energy from the boiler into the storage tank, and to avoid activating the thermal outflow protection

3.7.3 The boiler regulator and its installation

The boiler regulator is supplied in the packet.
Installation sequence:
- Install the control panel in the front of the boiler (see Section 4.2)
- Place the sensors in the (two) immersion tubes and gently bend and lock the capillary tube.
N.B.!
The thin sensor for the min. thermostat is embedded in the fan's immersion tube. The thin sensor is connected to boiler regulator min. thermostat B15.
- Set the min. thermostat to 90°C (see Section 3.7.5).
- Connect the cable to the circulation pump and the mains.
Phase + neutral + earth (230 V + earth).

3.7.4 Operating thermostat

The operating thermostat regulates the fan and must be set high, possibly at max. There is a stop screw behind the thermostat knob corresponding to the setting for a minimum operating temperature of about 85°C. The stop for the knob must be on the left side of the stop screw so that the boiler temperature is kept above 80°C.

3.7.5 Min. thermostat

There is a min. thermostat B15 in the boiler regulator which switches off the fan and the circulation pump M7 if the wood has burned out.

Setting: 90°C. the thin sensor must be embedded in the flue gas collection box immersion tube. This ensures that the fan is switched off relatively quickly after the boiler has burned out.

3.7.6 Circulation pump

The boiler regulator has two cables for the circulation pump. When using a charging pump and load valve, the charging pump must be connected to M7. Pump M2 does not have any thermostatic function. Pump M7 is regulated by the min. thermostat if connected to plug connection M7.

3.8 Commissioning the system

Bleed the system via the venting screw while filling it with water. Bleed again after heating as air forms after heating.

3.8.1 Check the system before you leave it.

1. Check that the boiler thermostat is functioning.
2. Check the overheating thermostat: a temporary connection is made between terminals 15 and 16 on terminal strip XI (see circuit diagrams Section 4). The fan must switch off when the boiler reaches the temperature at which the overheating thermostat is triggered. (The temporary connection between terminals 15 and 16 must be removed when the overheating thermostat has been checked). The overheating thermostat can be switched on again when the temperature has fallen by about 15°C after 10-15 minutes. The unlocking knob (H) (see Fig. 1.1.1) is located under a protective cap.

4 Technical specifications and circuit diagrams

4.1 Boiler technical specifications

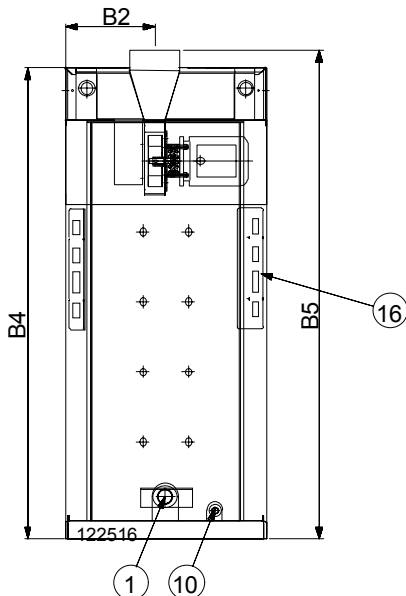
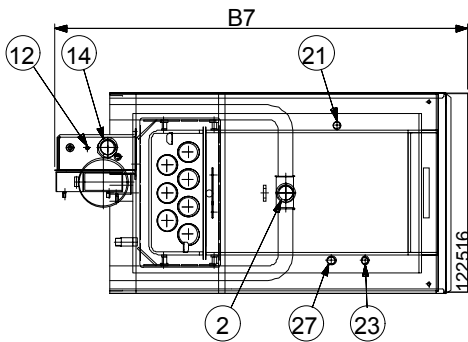
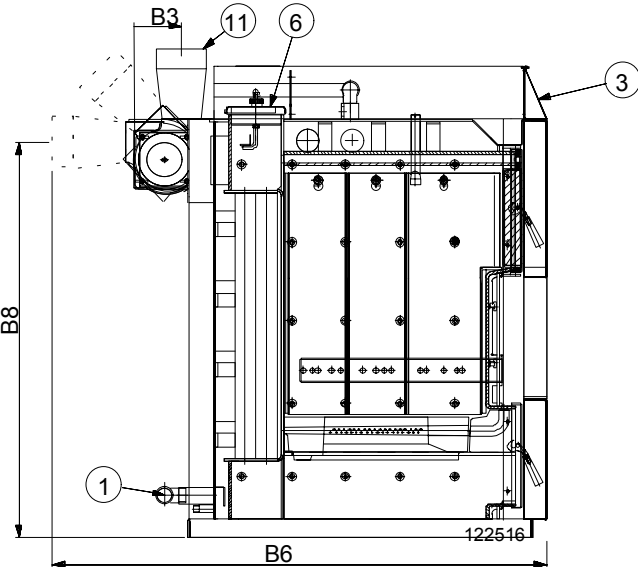

Solo Innova	Unit	20	30	50
1. Return flow	Inches	1¼	1¼	1¼
2. Outflow and expansion	Inches	1¼	1¼	1¼
3. Control panel	Volts	230	230	230
6. Cleaning cover	2 knurled screws	X	X	X
10. Filling/emptying	Inches	½	½	½
11. Flue gas pipe (exterior)	mm	149	149	149
12. Brackets for flue gas sensor		X	X	X
14. Brackets for O ₂ probe		X	X	X
16. Electrical connection		X	X	X
21. Brackets for control panel, closed immersion tube		X	X	X
23. Brackets for thermal outflow protect.	Inches	½	½	½
27. Brackets for control panel	Inches	½	½	½
Dimensions, B2	mm	265	265	360
Dimensions, B3	mm	145	145	145
Dimensions, B4	mm	1375	1375	1375
Dimensions, B5	mm	1425	1425	1425
Dimensions, B6	mm	1159	1440	1440
Dimensions, B7	mm	907	1188	1188
Dimensions, B8	mm	1150	1150	1150

Technical specifications:

Nominal heating output	kW	20	30	50
Fuel filling chamber depth	mm	379	550	550
Filling door 350 x 300 mm		✓	✓	✓
Volume combustion chamber	Litres	100	135	185
For wood length	Metres	1/3	½	½
Wood diameter, softwood	max. cm	10	10	10
Wood diameter, birch, beech	max. cm	15	15	15
Test pressure, boiler	bar	4,5	4,5	4,5
Test pressure, heat exchanger	bar	40	40	40

Installation data:

Depth A	mm	907	1188	1188
Width B	mm	584	584	694
Height C	mm	1375	1375	1375
Height (to chimney connection) D	mm	1425	1425	1425
Weight (empty)	kg	455	505	550
Water volume	Litres	100	130	180
Outer diameter exhaust stack	Ø mm	149	149	149
Reservoir volumes	Litres	1250	1500	2500

Environmental parameters and efficiency:

Dust in flue gas	mg/MJ	21	23	26
CO in flue gas	mg/MJ	195	185	198
NO _x	mg/MJ	100	128	101
Flue gas temperature at nominal output	°C	100	128	101
Utilisation	%	90.0	90.1	89.3
Required draught (Pascal)	N/m ²	10	10	10
Flue gas flow (min/max)	Kg/S	0.013	0.019	0.030

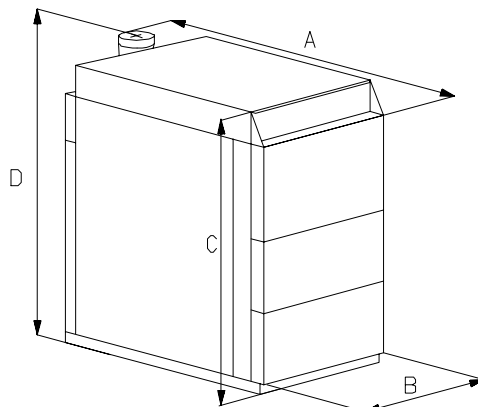

4.2 Circuit diagrams

4.2.1 Electrical connection

Electrical connection via the cable provided.

Description of functions see Section 3.7.2.

4.2.2 Circuit diagram legend

Fig.	Fig.		Fig.	F ig.	
B12	H	Overheating thermostat 100°C	M6	-	Fan
B15	-	Min. thermostat 90°C	M7	-	Charging pump for buffer tank (optional extra)
B16	I	Thermostat 85-93°C	N	-	Neutral conductor
L	-	Phase 230 V	S2	E	Switch for circulation pump (M2), system
F1	D	Fuse 6.3 A (5 x 20 mm)	S4	F	Fan switch
H2	-	In-operation light circulation pump (S2)	S7	N	Reset switch for fan
H4	-	In-operation light fan switch (S4)	W1	-	Connection cable
K2	-	Auxiliary relay holding current circuit	W3	-	Cable for circulation pump, system
K4	-	Time relay	W7	-	Cable for fan
K10	O	Switch for door interlock	W10	-	Earth cable
M2	-	Circulation pump, system (optional extra)	W11	-	Cable for buffer tank charging pump
			W13	-	Cable for door interlock
			X1	-	Terminal strip for various connections
			Y3	-	Solenoid coil

4.2.3 Wiring diagram

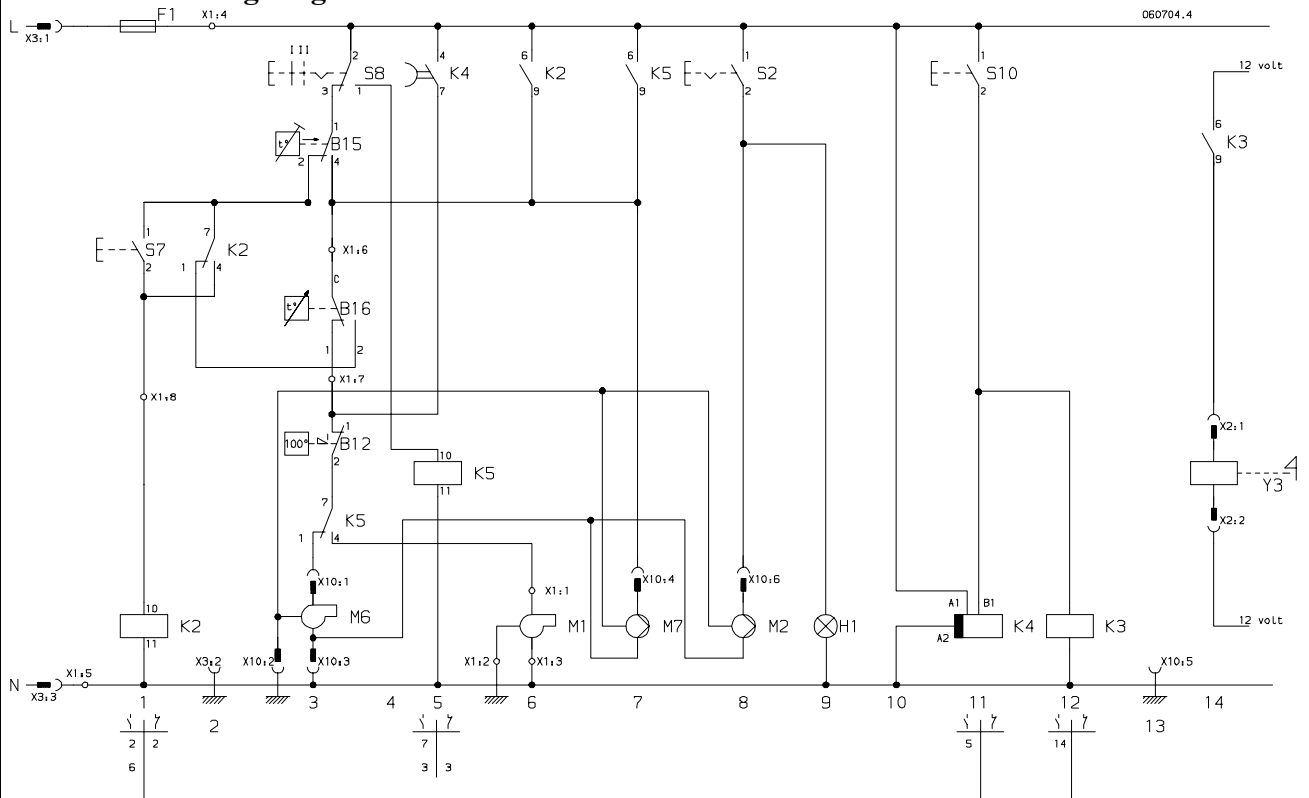

Fig. 4.2.3

4.2.4 Wiring diagram

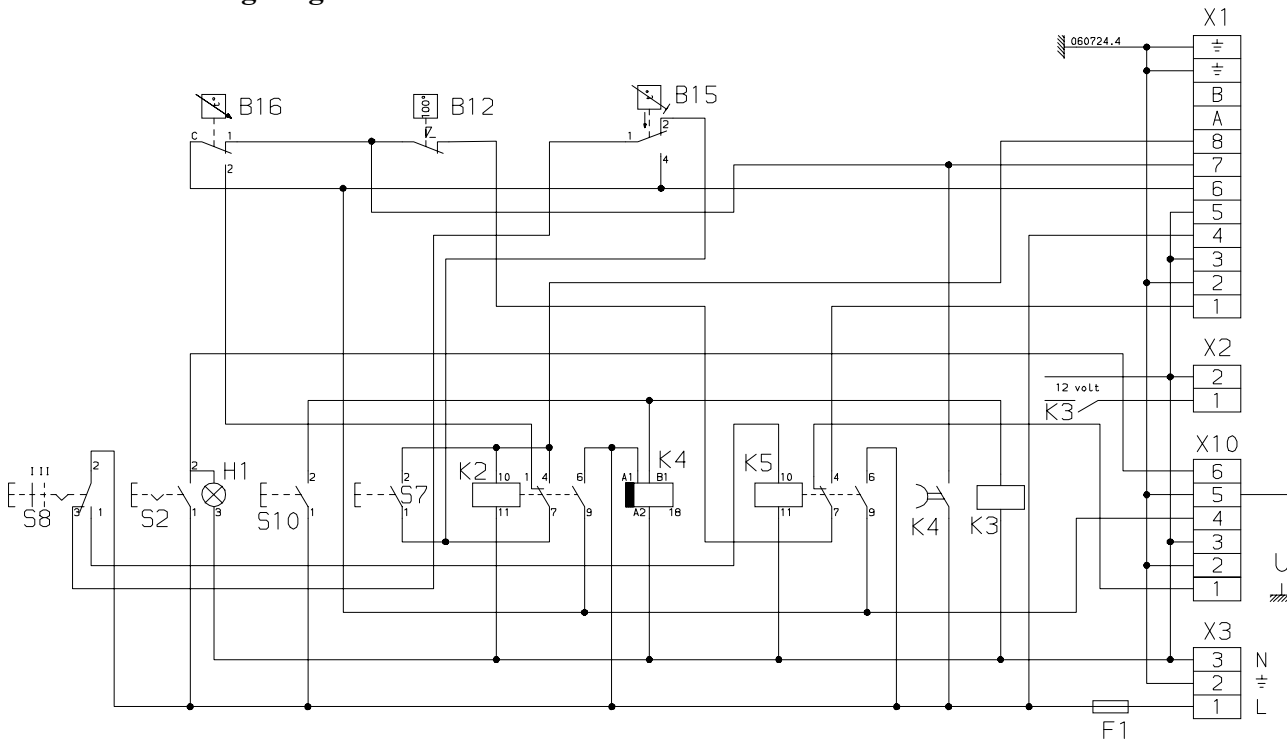
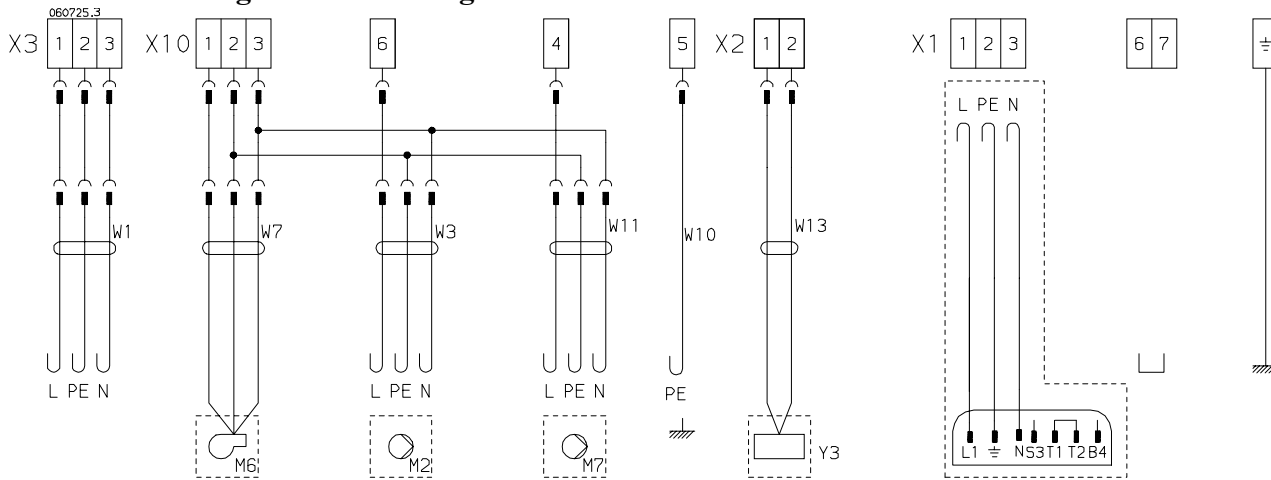

Fig. 4.2.4

4.2.5 Cabling connection diagram



Net	Blåser	Pumpe	Pumpe	Dørsikring	Brænder	Prøveklemme
Nätanslutning	Fläkt	Pump	Pump	Magnetlås	Brännar	Termostat test
Netz	Gebälse	Pumpe	Pumpe	Türsicherung	Brenner	Prüfklemme
Supply	Fan	Pump	Pump	Door safety	Burner	Thermostat Test
Réseau	Soufflante	Pompe	Pompe	Securité de porte par aimant	Brûleur	Borne de contrôle

⏏ = ⏏

PE= gul/grøn - gul/grøn - Gelb/grün - yellow/green
 A = sort - svart - Schwarz - noir - black
 L = brun - brun - Braun - brun - brown
 N = blå - blå - Blau - bleu - blue

Fig. 4.2.5

4.3 System layout

4.3.1 Solo Innova with buffer tank

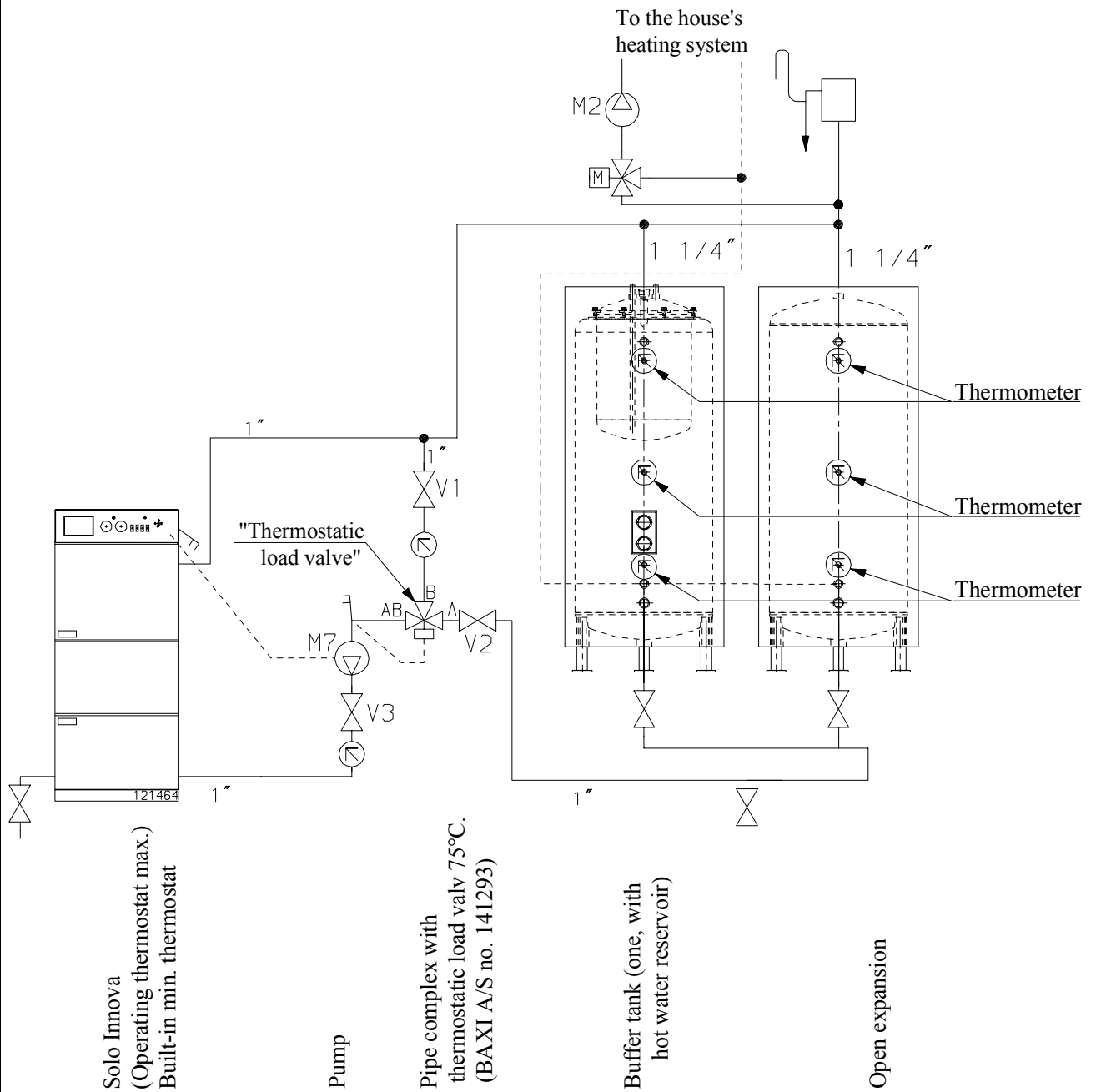

Load valve operation (set to 75°C)

The valve is open in direction B → AB until the water flowing through it reaches a temperature of 75°C.

At 75°C the water also begins to flow from A → AB.

The buffer tank is thus filled with water at a temperature of at least 75°C.

5 Installation protocol, boiler system

Installed by:

Boiler data:

Make, type designation:

BAXI Solo Innova No.:

Boiler output, kW:

Boiler installed and adjusted, date:

Guarantee certificate filled in and

sent to BAXI, date:

5.1 Measured and set values

	Date	Date	Date	Date	Date
Fuel type					
Secondary air setting					
Primary air setting					
Pump setting (system pump) step					
Pump setting (extra pump) set					
Other data/settings					
Setting done by: Signature					